

See discussions, stats, and author profiles for this publication at: <https://www.researchgate.net/publication/3193237>

Omnistereo: Panoramic stereo imaging

Article in IEEE Transactions on Pattern Analysis and Machine Intelligence · April 2001

DOI: 10.1109/34.910880 · Source: IEEE Xplore

CITATIONS

278

READS

3,529

3 authors:



Shmuel Peleg

Hebrew University of Jerusalem

220 PUBLICATIONS 14,924 CITATIONS

[SEE PROFILE](#)



Moshe Ben-Ezra

Massachusetts Institute of Technology

52 PUBLICATIONS 2,344 CITATIONS

[SEE PROFILE](#)



Yael Pritch

Google Inc.

44 PUBLICATIONS 4,093 CITATIONS

[SEE PROFILE](#)

Some of the authors of this publication are also working on these related projects:



Dynamic Temporal Alignment of Speech to Lips [View project](#)

Omnistereo: Panoramic Stereo Imaging

Shmuel Peleg, *Member, IEEE*, Moshe Ben-Ezra, and Yael Pritch

Abstract—An Omnistereo panorama consists of a pair of panoramic images, where one panorama is for the left eye and another panorama is for the right eye. The panoramic stereo pair provides a stereo sensation up to a full 360 degrees. Omnistereo panoramas cannot be photographed by two omnidirectional cameras from two viewpoints, but can be constructed by mosaicing together images from a rotating stereo pair. A more convenient approach to generate omnistereo panoramas is by mosaicing images from a single rotating camera. This approach also enables the control of stereo disparity, giving larger baselines for faraway scenes, and a smaller baseline for closer scenes. Capturing panoramic omnistereo images with a rotating camera makes it impossible to capture dynamic scenes at video rates and limits omnistereo imaging to stationary scenes. We, therefore, present two possibilities for capturing omnistereo panoramas using optics without any moving parts. A special mirror is introduced such that viewing the scene through this mirror creates the same rays as those used with the rotating cameras. A lens for omnistereo panorama is also introduced. The designs of the mirror and of the lens are based on curves whose caustic is a circle. Omnistereo panoramas can also be rendered by computer graphics methods to represent virtual environments.

Index Terms— Stereo imaging, panoramic imaging, image mosaicing.

1 INTRODUCTION

THE ultimate immersive visual environment should provide three elements: 1) Stereo vision, where each eye gets a different image appropriate to its location in space, 2) a complete 360 degrees view, allowing the viewer to look in any desired direction, and 3) allow free movement. All three elements can be obtained by moving a camera in the real world. Alternatively, these elements can be obtained with rendering of a full 3D model of a scene or from equivalent representations [9], [3], [6].

Omnistereo panoramas [5], [4], [12], [18], [11], [22] use a new scheme of image projection that enables both 1) stereo and 2) complete panoramic views simultaneously. No depth information or correspondences are necessary.¹ Viewers of omnistereo panoramas have the ability to freely view, in stereo, all directions.

The scene to image projection necessary for omnistereo panoramic imaging cannot be realized with a regular, single viewpoint camera. Omnistereo panoramas are, therefore, generated by mosaicing images taken with rotating cameras [5], [4], [12], [18]. As it is necessary to rotate a video camera a full circle in order to obtain a single omnistereo image, it is impossible to generate video-rate omnistereo movies.

To allow video rate omnistereo movies, two possible optical systems are presented without any moving parts. One system uses special mirrors and the other system uses

special lenses. Such optics is the first enabling step towards making omnistereo panoramic movies of real events: sports, travel, etc.

Short introductions are given in this section to panoramic imaging, stereo imaging, multiple viewpoint projections, and caustic curves. Section 2 discusses the multiple viewpoint projection used to create omnistereo panoramas. Capturing omnistereo panoramas in various methods is described in the following sections. Section 3 uses rotating cameras and, in Section 4, it is described how in this scheme, the stereo disparity can be adjusted for the distance of the scene. Section 5.2 presents a specially designed mirror. Section 5.3 presents a special lens. Section 6 describes synthetic generation of omnistereo panoramas for virtual environments using computer graphics methods.

1.1 Panoramic Images

A panoramic image is a wide field of view image, up to a full view of 360 degrees. Panoramas can be created on an extended planar image surface, on a cylinder, or on a sphere. Traditional panoramic images have a single viewpoint, also called the “center of projection” [8], [1], [19]. Panoramic images can be captured by panoramic cameras, by using special mirrors [10], [7], or by mosaicing a sequence of images from a rotating camera [19], [13].

Depth has been computed from panoramic images having two viewpoints, one above the other [2], [16]. However, since the disparity in this case is vertical, the images cannot be used for viewing by humans because our eyes are separated horizontally.

1.2 Visual Stereo

A stereo pair consists of two images of a scene from two different viewpoints. The disparity, which is the angular difference in viewing directions of each scene point between the two images, is interpreted by the brain as depth. Fig. 1 describes a conventional stereo setting. The disparity is a function of the point's depth and the distance between the eyes (*baseline*). Maximum disparity change,

1. We show that when depth or equivalent information can be available, omnistereo panoramas, whose stereo baseline adapts to the distances in the scene, can be obtained.

- S. Peleg is with the School of Computer Science and Engineering, The Hebrew University of Jerusalem, 91904 Jerusalem, Israel.
E-mail: peleg@cs.huji.ac.il.
- M. Ben-Ezra and Y. Pritch are with OmniStereo Ltd.
E-mail: {moshe, yael}@omnistereo.com.

Manuscript received 10 May 2000; revised 2 Nov. 2000; accepted 29 Nov. 2000.

Recommended for acceptance by R. Kumar.

For information on obtaining reprints of this article, please send e-mail to: tpami@computer.org, and reference IEEECS Log Number 112070.

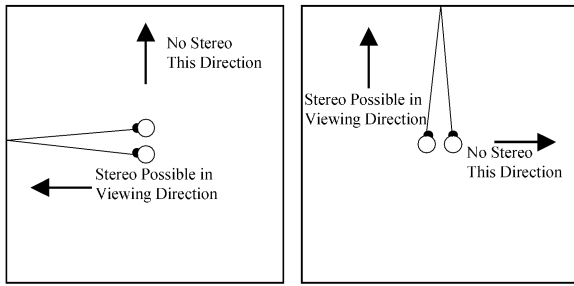

Fig. 1. No arrangement of two single-viewpoint images can give stereo in all viewing directions. For upward viewing, the two cameras should be separated horizontally and for sideways viewing, the two cameras should be separated vertically.

and, hence, maximum depth separation, is along the line in the scene whose points have equal distances from both eyes ("principal viewing direction"). No stereo depth separation exists for points along the extended baseline.

People can perceive depth from stereo images if the viewpoints of the two cameras generate horizontal disparity in a specific range. Human stereo fusion can be obtained with disparities of up to $\pm 0.5^\circ$.

Eye movement can change the absolute disparity by vergence. The point on which the eyes converge is called the point of fixation. Vergence cannot change depth perception, as depth perception is a function of relative disparities. However, vergence can make the viewing much more comfortable by setting the point of fixation close to the middle of the depth range at the viewing direction.

The maximum stereoscopic range for a human observer can be considerably improved with the use of suitable optical instrument, such as binoculars. The distance between the centers of the object glasses (the baseline) can reach 14cm (see Fig. 2), where in human vision the baseline is approximately 6.5 cm. The increased baseline and the lens magnification extends the human stereoscopic range when using binoculars.

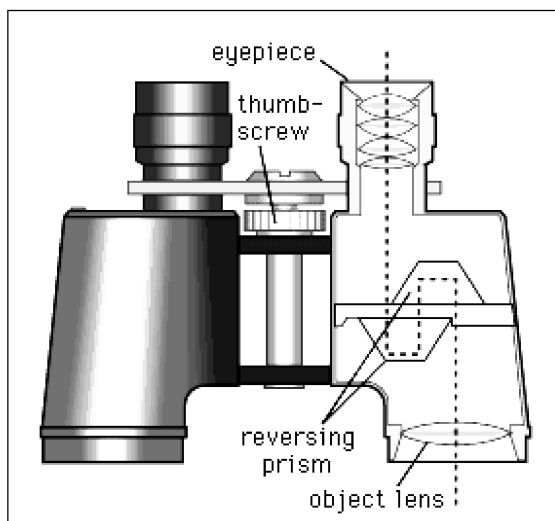

Fig. 2. In order to enhance stereo perception in distant scenes, the separation between the object lens in binoculars is usually larger than the separation between the eyepieces.

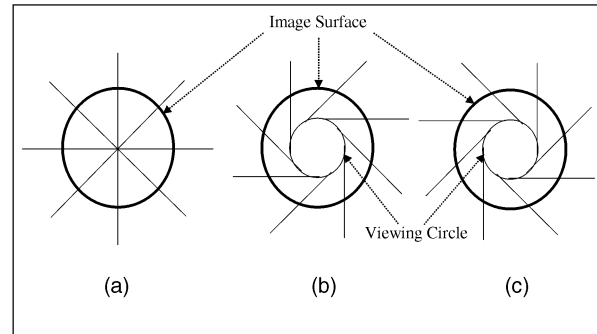

Fig. 3. Circular projections. The projection from the scene to the image surface is done along the rays tangent to the viewing circle. (a) Projection lines perpendicular to the circular imaging surface create the traditional single-viewpoint panoramic image. (b) and (c) Families of projection lines tangent to the inner viewing circle form the multiple-viewpoint circular projections.

2 CIRCULAR PROJECTIONS

Regular images are created by perspective projections: Scene points are projected onto the image surface along projection lines passing through a single point, called the "optical center" or the "viewpoint." Multiple viewpoint projections use different viewpoints for different viewing direction and were used mostly for special mosaicing applications. Effects that can be created with multiple viewpoint projections and mosaicing are discussed in [20], [15].

Omnistereo imaging uses a special type of multiple viewpoint projections, *circular projections*, where both the left-eye image and the right-eye image share the same cylindrical image surface. To enable stereo perception, the left viewpoint and the right viewpoint are located on an inner circle (the "viewing circle") inside the cylindrical image surface, as shown in Fig. 3. The viewing direction is on a line tangent to the viewing circle. The left-eye projection uses the rays on the tangent line in the clockwise direction of the circle, as in Fig. 3b. The right-eye projection uses the rays in the counterclockwise direction, as in Fig. 3c. Every point on the viewing circle, therefore, defines both a viewpoint and a viewing direction of its own.

The applicability of circular projections to panoramic stereo is shown in Fig. 4. From this figure, it is clear that the stereo baseline, i.e., the separation between the left and right viewpoints, is the largest possible for all scene points in all viewing directions. The stereo baseline is also identical for all viewing directions [17], unlike regular stereo that has a preferred viewing direction.

3 OMNISTEREO WITH A ROTATING CAMERA

Representing all stereoscopic views with two panoramic images presents a contradiction, as described in Fig. 1. When two panoramic images are captured from two different viewpoints, the disparity and the stereo perception will degrade as the viewing direction becomes closer to the baseline until no stereo will be apparent.

Generation of image-based stereo panoramas by rotating a stereo head having two cameras was proposed in [4], [18]. A stereo head with two cameras is rotated and two

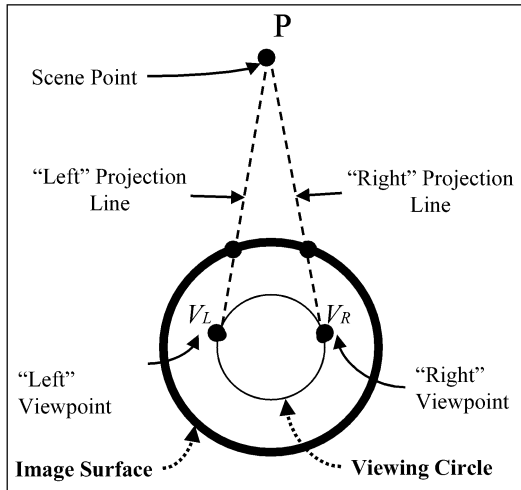

Fig. 4. Viewing a scene point with "left-eye" and "right-eye" projections. Stereo baseline, i.e., the separation between the left and right viewpoints is the largest possible on the viewing circle.

panoramic mosaics are created from the two different cameras. In this section, the generation of omnistereo panoramas with a single rotating camera is described.

3.1 Stereo Mosaicing with a Slit Camera

Panoramic stereo can be obtained using a single rotating camera [12], [5], [18]. This is done by simulating a "slit camera," as shown in Fig. 5. In such cameras, the aperture is a regular pinhole, as shown in Fig. 5a, but the film is covered except for a narrow vertical slit. The plane passing through the aperture and the slit determines a single viewing direction for the camera. The camera modeled in Fig. 5b has its slit fixed at the center and the viewing direction is perpendicular to the image surface. The camera modeled in Fig. 5c has its slit fixed at the side and the viewing direction is tilted from the perpendicular direction.

When a slit camera is rotated about a vertical axis passing through the line connecting the aperture and the slit, the resulting panoramic image has a single viewpoint (Fig. 3a). In particular, a single viewpoint panorama is obtained with rotations about the aperture. However, when the camera is rotated about a vertical axis directly behind

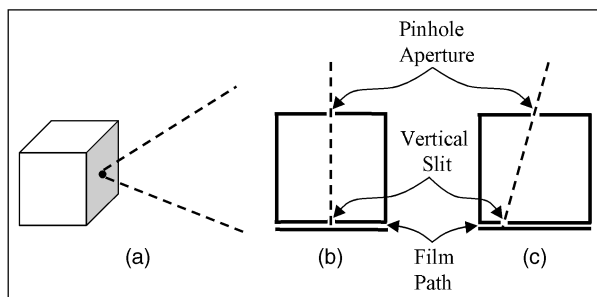

Fig. 5. Two models of slit cameras. (a) Side view. (b) and (c) Top view from inside the camera. While the camera is moving, the film is also moving in the film path. The locations of the aperture and the slit are fixed in each camera. (b) A vertical slit at the center gives a viewing direction perpendicular to the image surface. (c) A vertical slit at the side gives a viewing direction tilted from the perpendicular direction.

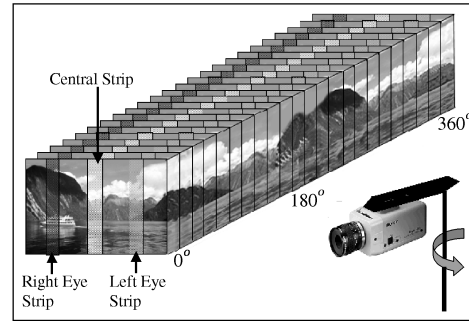

Fig. 6. Stereo Panoramas can be created using images captured with a regular camera rotating about an axis behind it. Pasting together strips taken from each image approximates the panoramic image cylinder. When the strips are taken from the center of the images an ordinary panorama is obtained. When the strips are taken from the left side of each image, the viewing direction is tilted counterclockwise from the image surface, obtaining the right-eye panorama. When the strips are taken from the right side of each image, the left-eye panorama is obtained.

the camera, and the vertical slit is not in the center, the resulting image has multiple viewpoints. The moving slit forms a cylindrical image surface. All projection lines, which are tilted from the cylindrical image surface, are tangent to some *viewing circle* on which all viewpoints are located. The slit camera in Fig. 5c, for example, will generate the circular projection described in Fig. 3b.

For omnistereo panoramas, we use a camera having two slits: one slit on the right and one slit on the left. The slits, which move together with the camera, form a single cylindrical image surface just like a single slit. The two projections obtained on this shared cylindrical image surface are exactly the circular projections shown in Fig. 3. Therefore, the two panoramic images, obtained by the two slits, enable stereo perception in all directions.

3.2 Stereo Mosaicing with a Video Camera

Stereo panoramas can be created with video cameras in the same manner as with slit cameras, by using vertical image strips in place of the slits [12]. When the video camera is rotated about an axis behind the camera, as shown in Fig. 6, the images create a $x-y-\alpha$ volume. The panoramic image is composed by combining together narrow strips, which together approximate the desired circular projection on a cylindrical image surface. The panoramic images are therefore $y-\alpha$ slices in the $x-y-\alpha$ volume. A $y-\alpha$ slice at the center represents a regular panorama, while $y-\alpha$ slices which are not at the center represent panoramas obtained with circular projections.

In manifold mosaicing [13], each image contributes a strip taken from its center to the mosaic. The width of the strip is a function of the displacements between frames. Stereo mosaicing is very similar, but each image contributes **two** strips, as shown in Fig. 6. Two panoramas are constructed simultaneously. The left panorama is constructed from strips located at the right side of the images, giving the "left-eye" circular projection. The right panorama, likewise, is

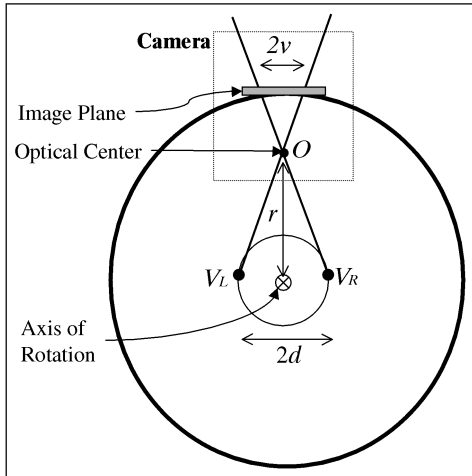

Fig. 7. A schematic diagram of the system to create omnistereo panoramas. A camera having an optical center "O" is rotated about an axis behind the camera. Note the "inverted" camera model, with the image plane in front of the optical center.

constructed from strips located at the left side of the images, giving the "right-eye" circular projection.

A schematic diagram of the process creating a pair of stereo panoramic images is shown in Fig. 7. A camera having an optical center O and an image plane is rotated about an axis behind the camera. Strips at the left of the image are seen from viewpoints V_R and strips at the right of the image are seen from viewpoints V_L . The distance between the two viewpoints is a function of the distance r between the rotation axis and the optical center, and the distance $2v$ between the left and right strips. Increasing the distance between the two viewpoints and, thus, increasing the stereo disparity, can be obtained by either increasing r or increasing v .

4 AUTOMATIC DISPARITY CONTROL

As shown in Fig. 8, the disparity in omnistereo panoramas generated with a rotating camera is a function of the the distance r between the rotation axis and the optical center (the "arm length"), the focal length f , and the separation $2v$

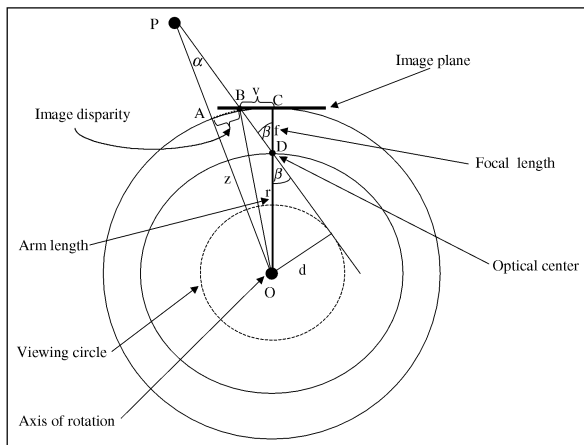

Fig. 8. Computing the disparities in an omnistereo mosaicing system.

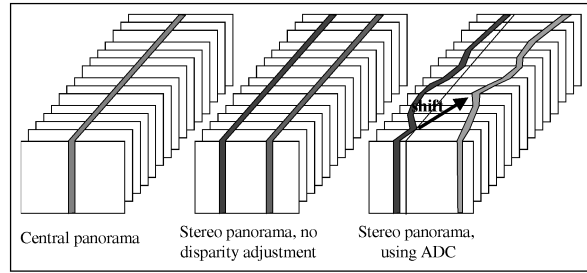

Fig. 9. Schematics of adjusting disparity by adjusting the strip separation. A set of images from a rotating camera is represented as an $x-y-\alpha$ volume. A regular panorama is a planar cut by an $y-\alpha$ plane in the center of the $x-y-\alpha$ volume. In omnistereo, each panorama is a planar cut by an $y-\alpha$ plane, but at the sides of the $x-y-\alpha$ volume and at fixed distance from the center. With automatic disparity control, the distance of the strip from the center is changing according to the desired baseline.

between the left and right strips. This relation is expressed as follows:

$$\begin{aligned}
 d &= R \sin(\beta) \\
 \beta &= \tan^{-1}\left(\frac{v}{f}\right) \\
 \alpha &= \sin^{-1}\left(\frac{d}{z}\right) = \sin^{-1}\left(\frac{R \sin(\tan^{-1}(\frac{v}{f}))}{z}\right).
 \end{aligned}
 \tag{1}$$

The length r of the arm between the rotation axis and the camera can be changed during the image capture time. Since a larger disparity is needed for the stereo perception of far away scenes, a longer arm will be used for such scenes compared to closer scenes. Alternatively, after the capture, if already completed, the distance $2v$ between the left and right strips can be changed during mosaic construction. Far away scenes will need larger distance between the strips. This section will describe how to measure the disparity during mosaic construction, and adjust it by adjusting the distance between the strips to make for best stereo perception.

A schematic description of this process appears in Fig. 9, where a set of images from a rotating camera is represented as an $x-y-\alpha$ volume. A panorama is a $y-\alpha$ slice in the $x-y-\alpha$ volume. Left and right omnistereo panoramas are each a $y-\alpha$ slice at the sides of the $x-y-\alpha$ volume and at fixed distance from the center. With the automatic disparity control, each panorama is also a slice in the $x-y-\alpha$ volume, but the distance of the strip from the center is changing according to the desired baseline. For far away regions, where the baseline should be larger to increase disparity, the strips will be further away from the center. In closer areas, where the baseline should be shortened to decrease disparity, the strips will be closer to the center. Note that since an object in the scene is visible at different rotation angles in the right strip and in the left strip, the two ADC slices are not symmetric, but are shifted with the angular difference.

4.1 Measuring Image Disparity

Image disparity is measured using the following steps:

1. The left and right panoramas are constructed with a fixed separation between the strips.

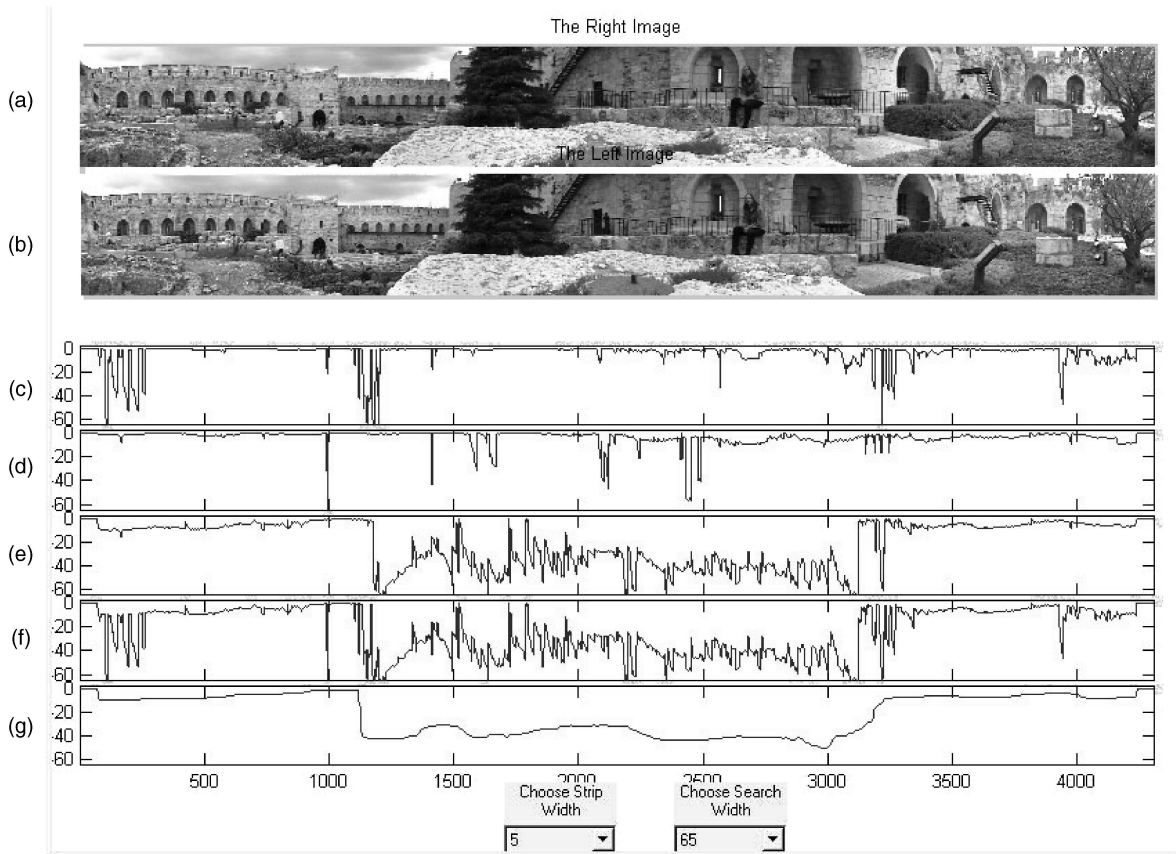

Fig. 10. Measuring disparities. (a) Original left eye panorama. (b) Original right eye panorama. (c), (d), and (e) Image disparities in pixels for the top, center, and bottom parts of the panorama. (f) Maximum disparity for each column. (g) Median filter of (f) to reduce the effect of noise.

2. The two panoramas are aligned such that objects at infinity will have no disparity.
3. Several horizontal image disparities are computed for each column between the two panoramas. The disparities are computed using correlation for a few windows along each column.
4. The maximum disparity for each column in the mosaic is selected, representing the closest object at the viewing direction corresponding to this column.
5. A median filter is applied to the disparity values to reduce the effects of noise.

This process is illustrated in Fig. 10.

4.2 Adjustment of Strip Separation

Once the disparity has been measured, we would like to adjust it for better stereo perception:

1. Keep the stereoscopic disparity within the fusion limits of the human brain. This capability is approximately $\pm 0.5^\circ$, which is about 30 pixels of image disparity.
2. Stretch the disparity in areas where all objects have a small disparity range and, hence, increasing the stereo depth sensation.
3. Maintain a monotonic relationship between the x coordinate of the mosaic and the rotation angle: The left-right relationship between every two mosaic points must represent the same left-right relationship between the two corresponding scene points.

Under the assumption that the strip separation is considerably smaller than the radius of rotation and the scene depth, the relation between the strip separation and image disparity is nearly linear.

For enhanced stereo, the maximal disparity which was computed in the previous section for each column, should be modified to be approximately 30 pixels. The separation between the strips is increased or decreased proportionately to the desired increase or decrease in disparity. To avoid sharp disparity changes, a median filter is applied to the obtained separation values to discard isolated peaks. The change in strip separation is always limited to changes that maintain the monotonic relationship between the x coordinate in the mosaic and the viewing directions of the objects.

Once the new separation between the strips is computed, new left and right panoramas are computed using the modified strip separation values. Note that since the left panorama and the right panorama view the same location in different frames, the modification of the separation between the strip in the right panorama and the left panorama for a certain column occurs at different frames, as seen in Fig. 9.

Fig. 11 shows the process of the disparity adaptation and the resulting panoramas are shown in Fig. 12. Zooming into a detail of the panorama is done in Fig. 13.

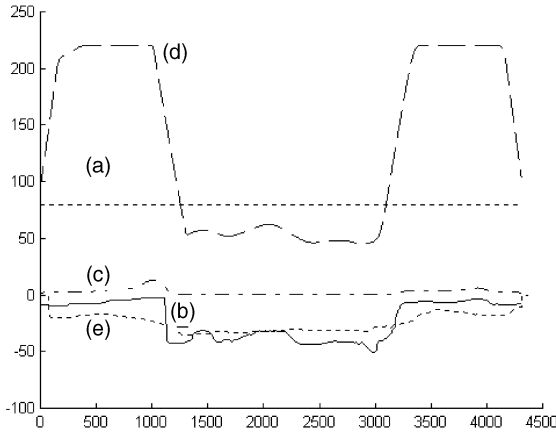

Fig. 11. Adjusting separation between strips. (a) Initial strip gap of 80 pixels. (b) Disparities measured on the mosaics using (a). (c) Correcting factor (see text). (d) Adjusted strip separation, larger for distant objects and smaller for close objects. (e) Disparities after adjustment of separation between strips.

5 SPECIAL OPTICS FOR OMNISTEREO IMAGING

Omnistereo imaging by mosaicing requires the scene to be static while the camera is rotating. This section describes the creation of circular projection images by optical devices. While not a complete practical solution for full omnistereo images, these techniques demonstrate that circular projections need not be obtained only by mosaicing.

The optical design follows the principle of caustic curves, which is summarized below.

5.1 Caustic Curves

Definition 1. The *envelope* of a set of curves is a curve C such that C is tangent to every member of the set.

Definition 2. A *caustic* is the envelope of rays emanating from a point source and reflected (or refracted) by a given curve.

A caustic curve caused by reflection is called a catacaustic, and a caustic curve caused by refraction is called a diacaustic [21]. In Fig. 17, the catacaustic curve given the mirror and the optical center is a circle. In Fig. 19 and in Fig. 20, given the lens and the optical center the diacaustic curve, is a circle.

5.2 A Mirror with a Circular Caustic

Regular cameras are designed to have a single viewpoint (“optical center”), following the perspective projection. In this section, we show how to create images having circular projections using a perspective camera and a spiral mirror. Full treatment of the computation of mirror can be found in [14].

The shape of the spiral mirror can be determined for a given optical center of the camera O , and a desired viewing circle V . The tangent to the mirror at every point has equal angles to the optical center and to the tangent to the circle (See Fig. 14). Each ray passing through the optical center

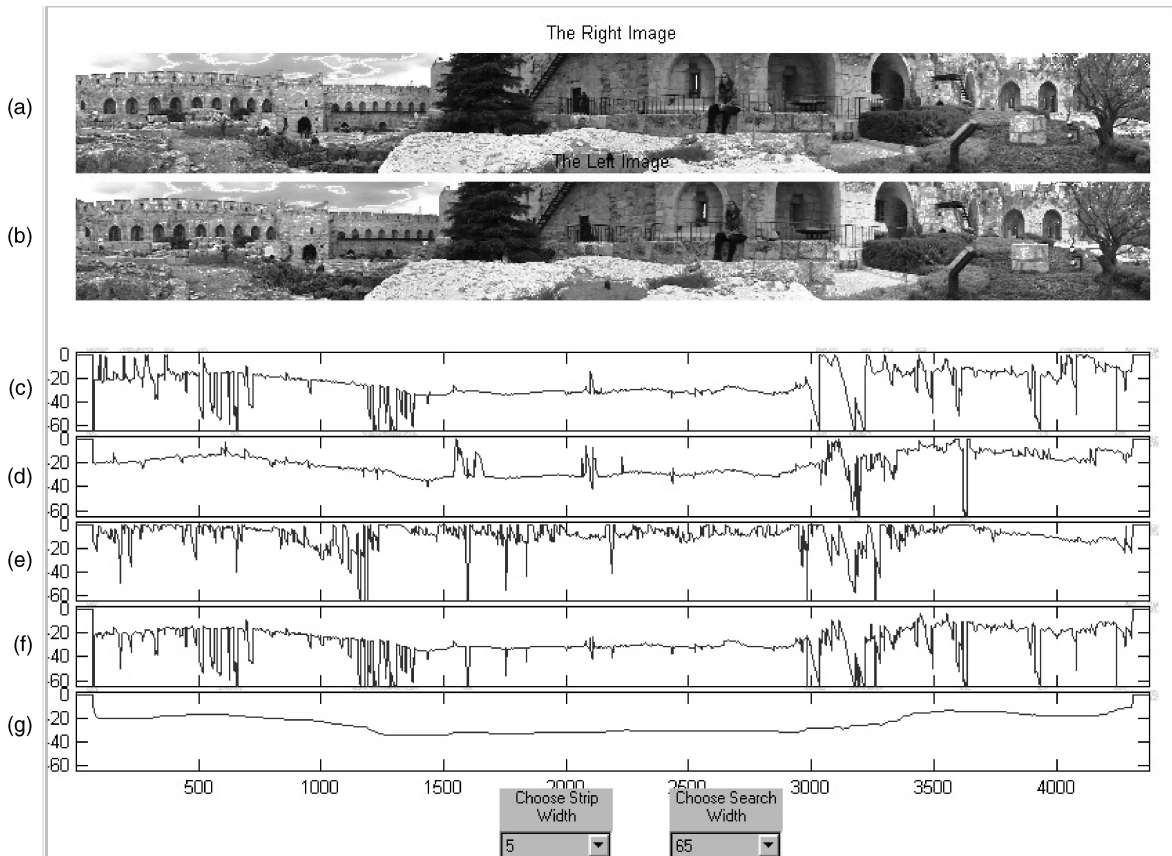

Fig. 12. Measuring disparities for the enhanced panoramas. (a) Original left eye panorama. (b) Original right eye panorama. (c), (d), and (e) Image disparities in pixels for the top, center, and bottom parts of the panorama. (f) Maximum disparity for each column. (g) Median filter of (f) to reduce the effect of noise.

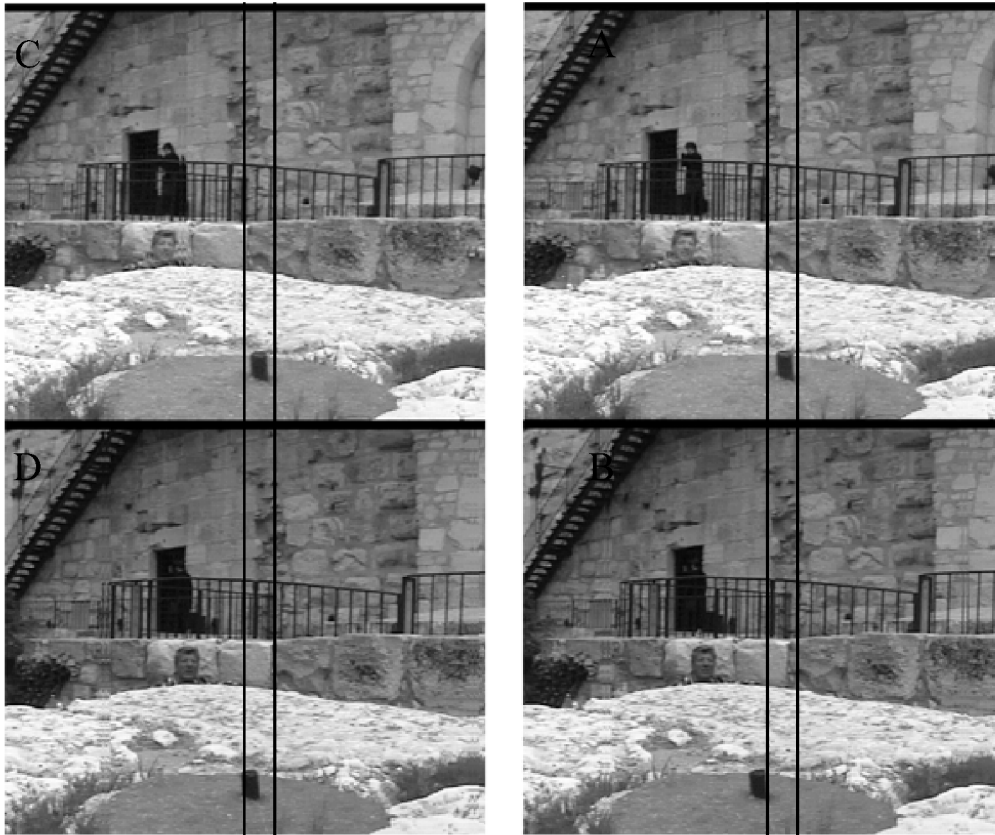

Fig. 13. A detail in the disparity adjustment. In the original stereo panorama on the right, the disparity of the black pole is too big for stereo fusion, since it is very close to the camera (left image is shown above the right image). After automatic disparity adjustment, the disparity is within the fusion range, enhancing stereo.

will be reflected by this mirror to be tangent to the viewing circle. This is also true in reverse: all rays tangent to the circle will be reflected to pass through the optical center. The mirror is, therefore, a curve whose catacaustic is a circle. For simplicity of computation, we assume that the optical center of the camera is located at the center of the viewing circle. Such location also helps to avoid occlusions, as everything inside the viewing circle is invisible to the circular projection.

The conditions at a surface patch of the spiral shaped mirror are shown in Fig. 15. The optical center is at the center of the viewing circle of radius R , and the mirror is defined by its distance $r(\theta)$ from the optical center. A ray passing through the optical center hits the mirror at an angle α to the normal and is reflected to be tangent to the viewing circle.

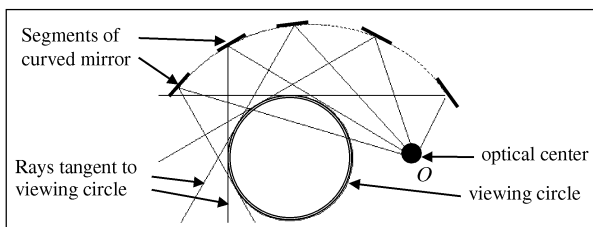

Fig. 14. The spiral mirror: All rays passing through the optical center O will be reflected by the mirror to be tangent to the viewing circle V . This implies that rays tangent to the viewing circle will be reflected to pass through the optical center.

Let the radius of the viewing circle be R and denote the vector from the optical center by $\bar{r}(\theta)$ and the mirror at direction θ (measured from the x -axis). The distance between the camera center and the mirror at direction θ

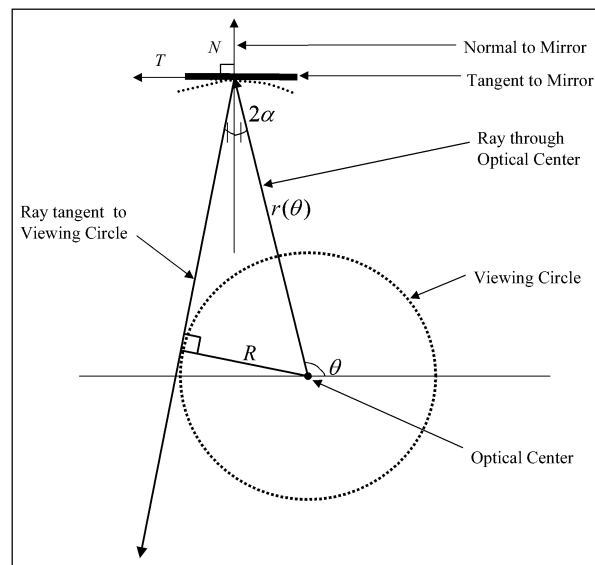

Fig. 15. Differential conditions at a mirror patch: The optical center is at the center of the viewing circle of radius R and the mirror is defined by its distance $r(\theta)$ from the optical center. A ray passing through the optical center hits the mirror at an angle α to the normal and is reflected to be tangent to the viewing circle.

will therefore be $r = r(\theta) = |\bar{r}|$. The ray conditions can be written as

$$\begin{aligned} R &= |\bar{r}| \sin(2\alpha) = |\bar{r}| 2\sin(\alpha) \cos(\alpha) \\ \sin(\alpha) &= \frac{|\mathbf{N} \times \bar{r}|}{|\bar{r}| \cdot |N|} \\ \cos(\alpha) &= \frac{N^T \bar{r}}{|\bar{r}| \cdot |N|}. \end{aligned} \quad (2)$$

Using those conditions, we can derive the following differential equation, where $\rho = \rho(\theta)$ is defined to be $\frac{r(\theta)}{R}$.

$$2\rho^2 \frac{\partial \rho}{\partial \theta} = \left(\frac{\partial \rho}{\partial \theta} \right)^2 + \rho^2. \quad (3)$$

This second degree equation in $\frac{\partial \rho}{\partial \theta}$ has two possible solutions:

$$\frac{\partial \rho}{\partial \theta} = \left\{ \begin{array}{l} \rho^2 + \rho\sqrt{\rho^2 - 1} \\ \rho^2 - \rho\sqrt{\rho^2 - 1} \end{array} \right\}. \quad (4)$$

The curve is obtained by integration on θ . The solution which fits our case is

$$\theta = \rho + \sqrt{\rho^2 - 1} + \arctan\left(\frac{1}{\sqrt{\rho^2 - 1}}\right). \quad (5)$$

With the constraint that $\rho > 1$.

The spiral mirror can also be represented by a parametric equation. Given the position of the camera (p_1, p_2) and the radius R of a viewing circle centered around the origin, points $(x(t), y(t))$ on the mirror can be represented as a function of a parameter t :

$$\begin{aligned} x &= \frac{\sin(t)(R^2 + p_1^2 - R^2 t^2 + p_2^2) - 2p_2 R - 2R^2 t \cos(t)}{2(-p_2 \cos(t) - Rt + \sin(t)p_1)} \\ y &= \frac{-\cos(t)(R^2 + p_1^2 - R^2 t^2 + p_2^2) + 2p_1 R - 2R^2 t \sin(t)}{2(-p_2 \cos(t) - Rt + \sin(t)p_1)}. \end{aligned} \quad (6)$$

When the camera is positioned at the origin, i.e., in the center of the viewing circle, the equations above simplify to:

$$\begin{aligned} x &= \frac{R(-\sin(t) + 2t \cos(t) + t^2 \sin(t))}{2t} \\ y &= \frac{-R(-\cos(t) - 2t \sin(t) + t^2 \cos(t))}{2t}. \end{aligned} \quad (7)$$

A curve satisfying these conditions has a spiral shape and Fig. 16 shows such a curve extended for three cycles. To avoid self-occlusion, a practical mirror will use only segments of this curve.

A spiral shaped mirror where the optical center is located at the center of the viewing circle is shown in Fig. 17.

The configuration where the optical center is at the center of the viewing circle is also convenient for imaging together the left image and the right image. Such a symmetric configuration is shown in Fig. 18. This configuration has a mirror symmetry and each mirror covers 132 degrees

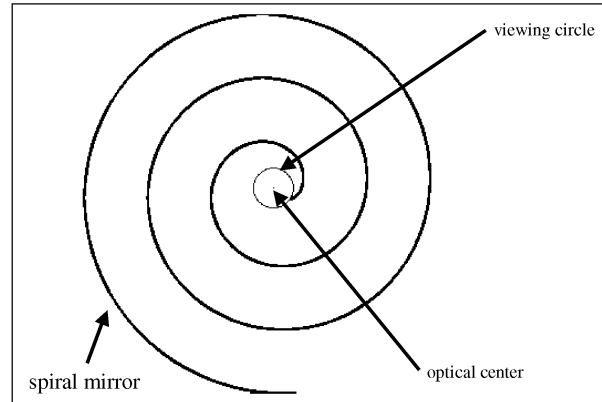

Fig. 16. A spiral shaped mirror extended for three full cycles. The catacaustic curve of this spiral is the small inner circle.

without self-occlusions. An *Omni Camera* [10], [7] can be placed at the center of the viewing circle to capture both the right image and the left image. Since this setup captures up to 132 degrees, three such cameras are necessary to cover a full 360 degrees.

5.3 A Spiral Lens

Circular projections can also be obtained with a lens whose diacaustic is a circle: The lens refracts the rays getting out of the optical center to be tangent to the viewing circle, as shown in Fig. 19. A lens can cover up to 360 degrees without self-occlusion depending on the configuration. The spiral of the lens is different from the spiral of the mirror. We have not yet computed an explicit expression for this curve and it is generated using numerical approximations.

It is possible to simplify the configuration and use multiple identical segments of a spiral lens, each capturing a small angular sector. Fig. 20 presents a configuration of 15 lenses, each covering 24 degrees. The concept of switching from one big lens to multiple smaller lenses that produce the same optical function was first used in the

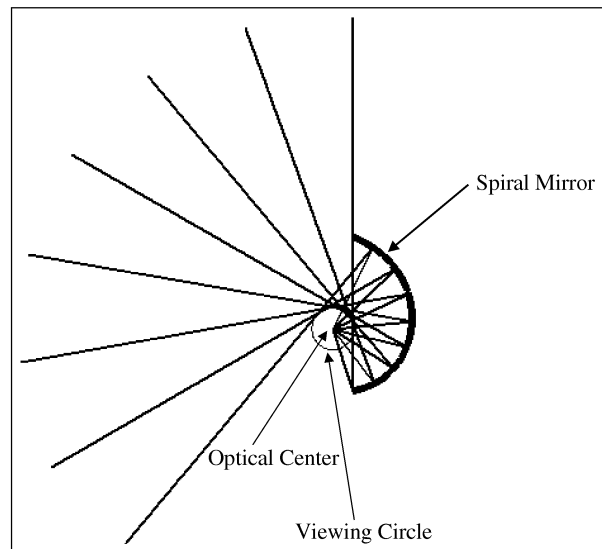

Fig. 17. A spiral mirror where the optical center is at the center of the viewing circle.

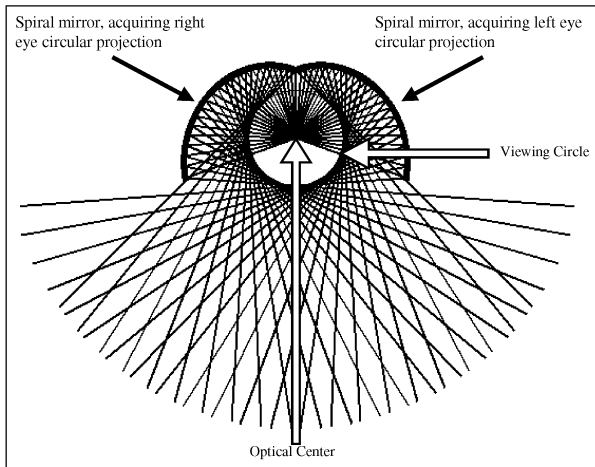

Fig. 18. Two spiral shaped mirrors sharing the same optical center and the viewing circle. One mirror for the left-circular-projection and one for the right-circular-projection.

Fresnel lens. In practice, a Fresnel-like lens can be constructed for this purpose having thousands of segments. A convenient way to view the entire panorama is by placing a panoramic omnidirectional camera [10], [7] at the center of the lens system, as shown in Fig. 21.

The requirement that the cylindrical element (e.g., as in Fig. 20) just bends the rays in the horizontal direction is accurate for rays that are in the same plane of the viewing circle. But this is only an approximation for rays that come from different vertical directions. Examine, for example, Fig. 22. Let us examine the rays for viewpoint R . Ray A is in the horizontal plane that includes the viewing circle V . It is deflected by the Fresnel lens into ray a and passes through the center O of the viewing circle, the location of the optical center of the panoramic camera. Ray B , which also passes through viewpoint R , but from a higher elevation, is also deflected by the same horizontal angle, but will not reach O . Instead, Ray B is deflected into ray d , which can intersect the horizontal plane closer or further to the Fresnel lens than O . In order for ray B to be deflected into Ray c , that intersects O , the Fresnel lens should deflect it also in the vertical direction. Each elevation should have a different vertical deflection. A possible arrangement is that the

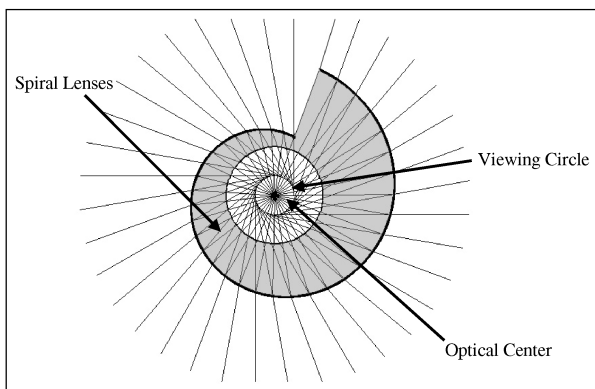

Fig. 19. A spiral shaped lens. The diacaustic of the lens' outer curve is a circle (the viewing circle). Capturing the panorama can be done by an omnidirectional camera at the center of the viewing circle.

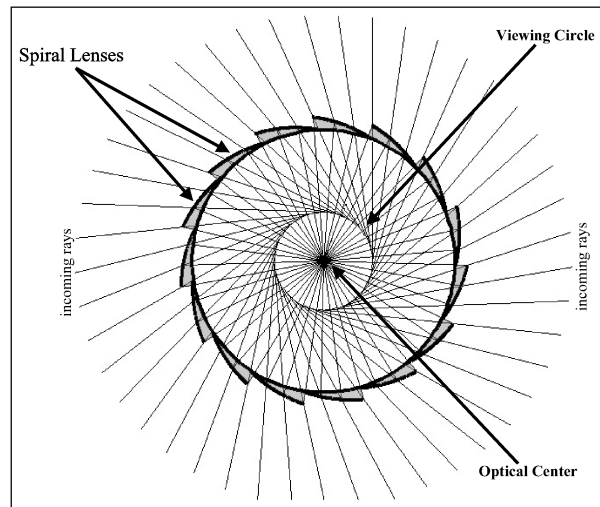

Fig. 20. A collection of identical short spiral lens positioned on a circle. A Fresnel-like lens can be built with thousands of lens segments. Capturing the panorama can be done by an Omni Camera at the center of the viewing circle.

cylindrical Fresnel lens has vertical elements on one side that take care of the horizontal deflection (which is constant) and on the other side it has horizontal elements that take care of the horizontal deflection (which is different for every elevation).

Note that the proposed optical configuration is not a blueprint for the construction of an omnistereo camera, but only a schematic principle for the creation of circular projections using optics. Practical engineering issues, like the handling of chromatic aberration or the creation of a pair of left-right image pairs, still need to be solved before a camera is built.

6 RENDERING OMNISTEREO PANORAMAS

Previous sections presented the capture of omnistereo images of real scenes. This chapter presents the rendering of omnistereo images of virtual scenes given their 3D model.

Conventional rendering, e.g., ray-tracing, uses a single-viewpoint perspective projection onto a planar image

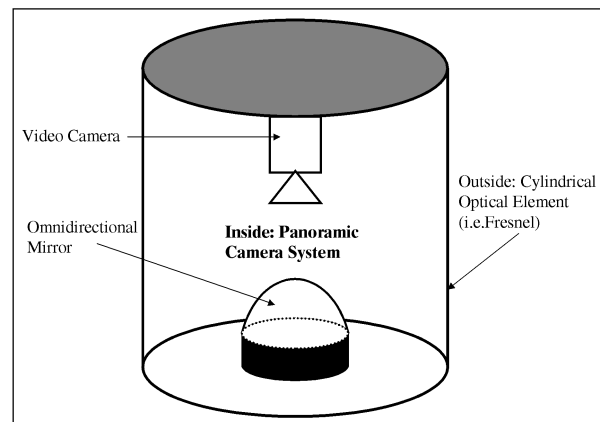

Fig. 21. An omnidirectional camera at the center of the viewing circle enables the creation of a full 360 degrees left-image or a right-image.

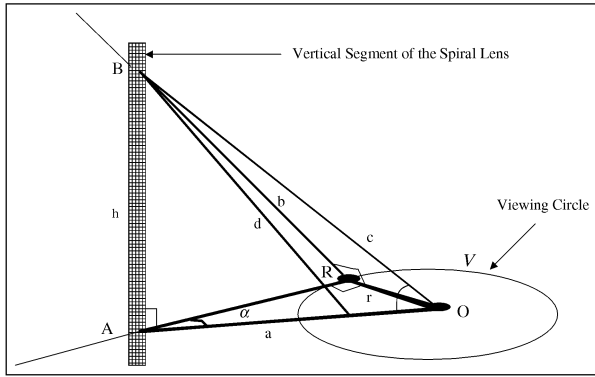

Fig. 22. Vertical deflection of rays is necessary in order to assure that every viewing direction will have a single viewpoint on the viewing circle.

surface. When using a polygonal approximation for the panoramic viewing cylinder (or sphere), each face of this polygonal approximation can be rendered separately from a different viewpoint. A schematic diagram is shown in Fig. 23, where the image cylinder is approximated by vertical faces. Circular projection of the entire face is approximated by rendering it from a viewpoint suitable for circular projection of the center of the face. Reasonable quality is obtained when using one face for every 1-2 degrees, or approximately 200-400 faces for the entire cylinder.

When generating a stereo panorama, the radius r of the image cylinder determines the resolution of the rendered panorama, and the radius d of the viewing circle determines the stereo baseline (which is approximately $2d$). The human stereo baseline, the distance between the eyes, is fixed at approximately 6.5cm, but in rendering we have the freedom to use a larger baseline for far away scenes and smaller baseline for closer scenes.

From the above parameters of r and d , we can determine the parameters of the cameras used for rendering, as displayed in Fig. 24 for the right-eye panorama. Generation of the left-eye panorama is symmetric.

The viewpoints used for rendering the faces of the polygonal approximation to the image cylinder will be

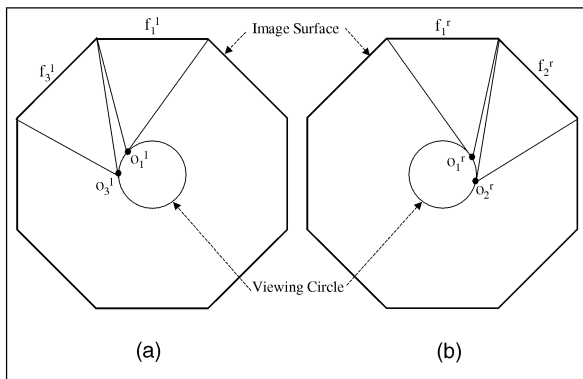

Fig. 23. Cylindrical panoramas are rendered using polygonal approximation. Each face is rendered from a viewpoint suitable for the circular projection of its center. Face f_1^r in the right panorama is generated from viewpoint o_1^r on the viewing circle and face f_1^l in the left panorama is generated from viewpoint o_1^l on the viewing circle.

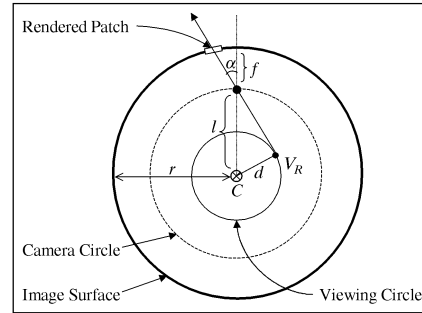

Fig. 24. Determination of the projection parameters for rendering a right-eye panorama.

located on a "camera circle" of radius l , such that $d \leq l < r$. Given a face to be rendered, the viewpoint should be located on the camera circle such that the center of the face is viewed at angle $\alpha = \sin^{-1} d/l$ from the radius connecting the viewpoint to the center C . For example, when $l = d$, the viewpoint is on the viewing circle, and the viewing direction is tangent to the viewing circle. The preferred direction for the optical axis is to be parallel to the radius connecting the center of the rendered face to C . But other configurations give reasonable results and the optical axis can point to the rendered face, or be on the radius connecting the viewpoint to C . In the latter case, the focal length will be $f = r - l$.

7 STEREO PAIRS FROM STEREO PANORAMAS

When viewing the stereo panorama on a flat screen, like a computer or television monitor, or a head-mounted display, the panoramic image is projected from the cylinder onto a plane. While the cylindrical panoramic stereo images are created using circular projections (Figs. 3b and 3c), they should be projected into the planar image surface using a central projection (Fig. 3a). As seen in Fig. 25, central projections introduce fewer distortions and are symmetrical for the left and right images. A central projection about the center of the cylinder, with the image plane tangent to the panoramic cylinder, is a natural projection; it is symmetric for the left side and the right side of the image as well as symmetric between the left-eye and right-eye projections. This projection also preserves the angular disparity that exists on the cylinder for a viewer located at the center of

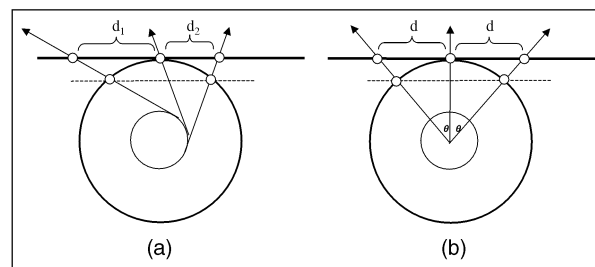

Fig. 25. (a) Projecting the cylindrical panorama using the original circular projection creates a distorted planar image. (b) A central projection creates a symmetrical planar image which preserves the disparity for a viewer located at the center of the cylinder.

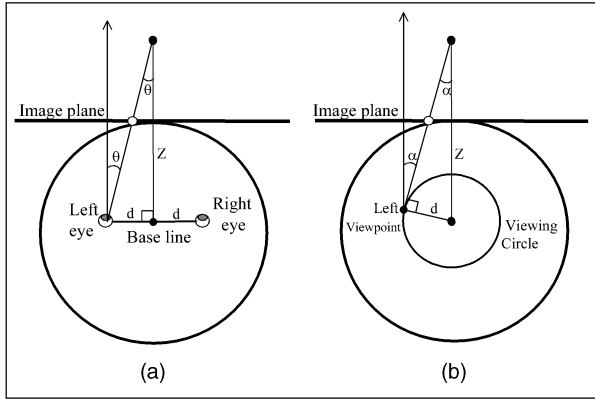

Fig. 26. Comparing disparities between cylindrical panoramas and conventional stereo pairs. (a) The disparity of conventional stereo is 2θ where $\theta = \tan^{-1}(\frac{d}{Z})$. (b) The disparity of stereo panorama is 2α where $\alpha = \sin^{-1}(\frac{d}{Z})$. This disparity is preserved by the central projection of the panorama onto a planar image.

the cylindrical projection and, hence, preserves the depth perception.

Below is further examination of the process that generates the cylindrical panoramas using the multiple viewpoint circular projection and creates planar images from the cylindrical panoramas using the single viewpoint central projection. Fig. 26 describes the relation between a conventional stereo pair and cylindrical panoramic stereo having the same base line of $2d$. For a point at depth Z , the disparity of conventional stereo is 2θ , where $\theta = \tan^{-1}(\frac{d}{Z})$. The disparity of stereo panorama is 2α , where $\alpha = \sin^{-1}(\frac{d}{Z})$. This disparity is preserved by the central projection of the panorama onto a planar image. Since the stereo disparities that can be fused by a human viewer are small, $\sin(x) \approx \tan(x)$ and the disparities are practically the same.

8 LEFT-RIGHT VERGENCE

The imaging process introduces a shift between the left view panorama and the right view panorama. This shift is not related to the depth parallax and, in particular, points at infinity may not be aligned. Since the stereo disparity of points at infinity should be zero, aligning the points at infinity will correct this shift. Fig. 27 illustrates this process. A point P_∞ located at infinity is projected by a reference central projection into point S and by the left circular projection into P'_∞ . The angle β between these points is the misalignment of the left circular projection relative to the reference central projection. $\beta = \angle(SCP'_\infty) = \angle(CP'_\infty V_R) = \sin^{-1}(R/L)$. For vergence on points at infinity, such that they will be aligned in both panoramas, the left panorama and the right panorama should each be rotated towards the reference circular projection by β .

9 CONCLUDING REMARKS

The theory of omnistereo imaging has been presented. This includes the special circular projection that can provide panoramic stereo in 360 degrees and several methods to realize this projection. The simplest method that was presented to create Omnistereo panoramas is mosaicing.

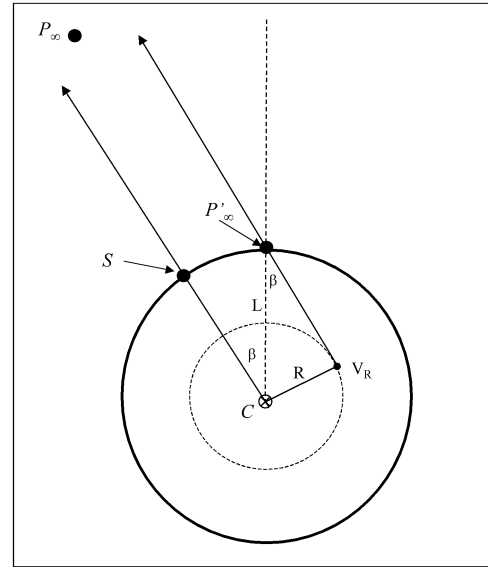

Fig. 27. Vergence for left circular projection.

Mosaicing by pasting strips from a rotating camera is applicable to static scenes. In addition, two optical systems, having no moving parts, were presented for capturing stereo panoramic video. One system is based on spiral mirrors and the second system is based on spiral lenses. While not constructed yet at the time of writing this paper, the optical systems represent possible principles that may enable to capture real-time movies having the stereo panoramic features. Omnistereo panoramas can also be rendered from models of virtual scenes.

ACKNOWLEDGMENTS

The authors would like to thank Tanya Matskewich and Eisso Atzema (University of Maine) for their help in deriving the expressions defining the spiral mirror. Portions of this work were supported by the Isreal Science Foundation grant 612 and by the Israeli Ministry of Science grant 2097/1/99.

REFERENCES

- [1] S. Chen, "Quicktime VR—An Image-Based Approach to Virtual Environment Navigation," *Proc. SIGGRAPH '95*, pp. 29-38, Aug. 1995.
- [2] J. Gluckman, S. Nayar, and K. Thoresz, "Real-Time Omnidirectional and Panoramic Stereo," *Proc. DARPA Image Understanding Workshop '98*, pp. 299-303, Nov. 1998.
- [3] S. Gortler, R. Grzeszczuk, R. Szeliski, and M. Cohen, "The Lumigraph," *Proc. SIGGRAPH '96*, pp. 43-54, Aug. 1996.
- [4] H.-C. Huang and Y.-P. Hung, "Panoramic Stereo Imaging System with Automatic Disparity Warping and Seaming," *Graphical Models and Image Processing*, vol. 60, no. 3, pp. 196-208, May 1998.
- [5] H. Ishiguro, M. Yamamoto, and S. Tsuji, "Omni-Directional Stereo," *IEEE Trans. Pattern Analysis and Machine Intelligence*, vol. 14, no. 2, pp. 257-262, Feb. 1992.
- [6] S. Kang and R. Szelisky, "3D Scene Data Recovery Using Omnidirectional Multibaseline Stereo," *Proc. IEEE Conf. Computer Vision and Pattern Recognition*, pp. 364-370, June 1996.
- [7] T. Kawanishi, K. Yamazawa, H. Iwasa, H. Takemura, and N. Yokoya, "Generation of High-Resolution Stereo Panoramic Images by Omnidirectional Sensor Using Hexagonal Pyramidal Mirrors," *Proc. 14th Int'l Conf. Pattern Recognition*, pp. 485-489, Aug. 1998.

- [8] S. Mann and R. Picard, "Virtual Bellows: Constructing High Quality Stills from Video," *Proc. First IEEE Int'l Conf. Image Processing*, vol. I, pp. 363-367, Nov. 1994.
- [9] L. McMillan and G. Bishop, "Plenoptic Modeling: An Image-Based Rendering System," *Proc. SIGGRAPH '95*, pp. 39-46, Aug. 1995.
- [10] S. Nayar, "Catadioptric Omnidirectional Cameras," *Proc. IEEE Conf. Computer Vision and Pattern Recognition*, pp. 482-488, June 1997.
- [11] S. Nayar and A. Karmarkar, "360 x 360 Mosaics," *Proc. IEEE Conf. Computer Vision and Pattern Recognition*, pp. 388-395, June 2000.
- [12] S. Peleg and M. Ben-Ezra, "Stereo Panorama with a Single Camera," *Proc. IEEE Conf. Computer Vision and Pattern Recognition*, pp. 395-401, June 1999.
- [13] S. Peleg and J. Herman, "Panoramic Mosaics by Manifold Projection," *Proc. IEEE Conf. Computer Vision and Pattern Recognition*, pp. 338-343, June 1997.
- [14] Y. Pritch, M. Ben-Ezra, and S. Peleg, "Optical Projections for Panoramic Stereo," *Foundations of Image Processing and Computer Vision: A Festschrift in Honor of Prof. Azriel Rosenfeld*, L. Davis, ed., Kluwer, 2001.
- [15] P. Rademacher and G. Bishop, "Multiple-Center-of-Projection Images," *Proc. SIGGRAPH '98*, pp. 199-206, July 1998.
- [16] J. Shimamura, N. Yokoya, H. Takemura, and K. Yamazawa, "Construction of an Immersive Mixed Environment Using an Omnidirectional Stereo Image Sensor," *Proc. IEEE Workshop Omnidirectional Vision*, pp. 62-69, June 2000.
- [17] H. Shum, A. Kalai, and S. Seitz, "Omnivergent Stereo," *Proc. Seventh Int'l Conf. Computer Vision*, pp. 22-29, Sept. 1999.
- [18] H. Shum and R. Szeliski, "Stereo Reconstruction from Multiperspective Panoramas," *Proc. Seventh Int'l Conf. Computer Vision*, pp. 14-21, Sept. 1999.
- [19] R. Szeliski, "Video Mosaics for Virtual Environments," *IEEE Computer Graphics and Applications*, vol. 16, no. 2, pp. 22-30, 1996.
- [20] D. Wood, A. Finkelstein, J. Hughes, C. Thayer, and D. Salesin, "Multiperspective Panoramas for Cel Animation," *Proc. SIGGRAPH '97*, pp. 243-250, Aug. 1997.
- [21] R.C. Yates, *A Handbook on Curves and Their Properties*, rev. ed., Nat'l Council of Teachers of Math., 1952, reprinted, 1974.
- [22] T. Naemura, M. Kaneko, and H. Harashima, "Multi-User Immersive Stereo," *Proc. IEEE 1998 Int'l Conf. Image Processing*, vol. 1, pp. 903-907, Oct. 1998.



Shmuel Peleg received the BSc degree in mathematics from The Hebrew University of Jerusalem, Israel, in 1976 and the MSc and PhD degrees in computer science from the University of Maryland, College Park, in 1978 and 1979, respectively. He has been a faculty member at the Hebrew University of Jerusalem since 1980 and has held visiting positions at the University of Maryland, New York University, and the Sarnoff Corporation. He is a member of the IEEE.

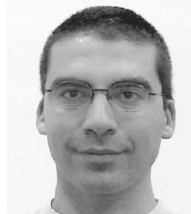

Moshe Ben-Ezra received the BSc, MSc, and PhD degrees in computer science from The Hebrew University of Jerusalem, Israel, in 2000. His research interests are computer vision with emphasis on real-time and optics. He is now with OmniStereo Ltd.



Yael Pritch received the BSc degree and MSc degrees in computer science from The Hebrew University of Jerusalem, Israel, in 1998 and 2000, respectively. Her research interests are in computer vision with emphasis on motion analysis and the construction of panoramic stereoscopic images. She is now with OmniStereo Ltd.